

DESCRIPTION

The XR5027 is a current mode monolithic buck voltage converter. Operating with an input range of 3.8V-24V, the XR5027 delivers 2A of continuous output current with two integrated N-Channel MOSFETs. At light loads, regulators operate in low frequency to maintain high efficiency and low output ripple.

The XR5027 guarantees robustness with short circuit protection, thermal protection, current run-away protection, and input under voltage lockout.

The XR5027 is available in a 6-pin SOT23 package, which provides a compact solution with minimal external components.

FEATURES

- 3.8V to 24V operating input range
2A output current
- Up to 95% efficiency
- High efficiency (>80%) at light load
- Fixed 1.4MHz Switching frequency
- Input under voltage lockout
- Start-up current run-away protection
- Over current protection and Hiccup
- Thermal protection
- Available in SOT23-6 package

APPLICATIONS

- Distributed Power Systems
- Networking Systems
- FPGA, DSP, ASIC Power Supplies
- Green Electronics/ Appliances
- Notebook Computers

TYPICAL APPLICATION

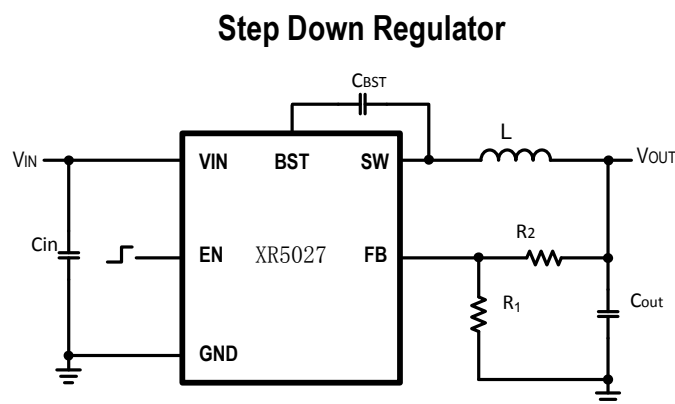

ORDER INFORMATION

| DEVICE ¹⁾ | PACKAGE | TOP MARKING ²⁾ |
|----------------------|---------|---------------------------|
| XR5027SOTB#TRPBF | SOT23-6 | XRKCX YWLLL |

Notes : : :

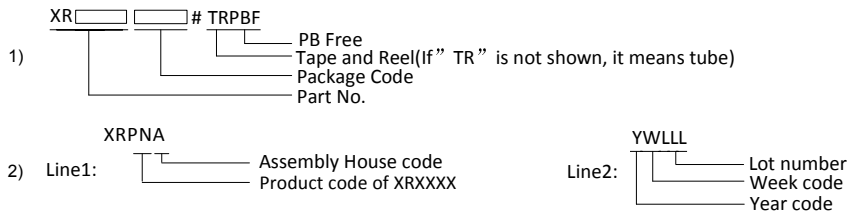

PIN CONFIGURATION

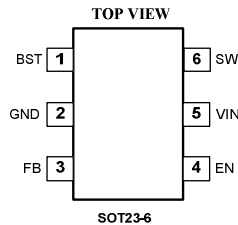

ABSOLUTE MAXIMUM RATING^{1)1)))}

| | |
|--------------------------------------|------------------|
| VIN, EN, SW Pin | -0.3V to 25V |
| BST Pin | SW-0.3V to SW+5V |
| All other Pins | -0.3V to 6V |
| Junction Temp. ²⁾³⁾ | 150°C |
| Lead Temperature | 260°C |

RECOMMENDED OPERATING CONDITIONS

| | |
|--------------------------------------|----------------|
| Input Voltage VIN | 3.8V to 24V |
| Output Voltage Vout | 0.8V to VIN-3V |
| Operating Junction Temperature | -40°C to 125°C |

THERMAL PERFORMANCE^{4)4)))}

| | | | |
|---------------|----------------|----------------|---------------|
| SOT23-6 | θ_{JUA} | θ_{JUC} | 220...130°C/W |
|---------------|----------------|----------------|---------------|

Note : : :

- Exceeding these ratings may damage the device.
- The XR5027 guarantees robust performance from -40°C to 150°C junction temperature. The junction temperature range specification is assured by design, characterization and correlation with statistical process controls.
- The XR5027 includes thermal protection that is intended to protect the device in overload conditions. Thermal protection is active when junction temperature exceeds the maximum operating junction temperature. Continuous operation over the specified absolute maximum operating junction temperature may damage the device.
- Measured on JESD51-7, 4-layer PCB

ELECTRICAL CHARACTERISTICS

| <i>V_{IN}=12V, T_A=25 °C, Unless otherwise stated.</i> | | | | | | |
|--|--------------------------|--|------|------|------|------|
| Item | Symbol | Conditions | Min. | Typ. | Max. | Unit |
| V _{IN} Under Voltage Lock-out Threshold | V _{IN_MIN} | V _{IN} rising | 3.3 | 3.55 | 3.8 | V |
| V _{IN} Under voltage Lockout Hysteresis | V _{IN_MIN_HYST} | | | 450 | | mV |
| Shutdown Supply Current | I _{SD} | V _{EN} =0V | | 0.1 | 1 | μA |
| Supply Current | I _Q | V _{EN} =5V, V _{FB} =1.2V | | 120 | 150 | μA |
| Feedback Voltage | V _{FB} | 3.8V<V _{VIN} <24V | 776 | 800 | 824 | mV |
| Top Switch Resistance ⁵⁾ | R _{DS(ON)T} | | | 130 | | mΩ |
| Bottom Switch Resistance ⁵⁾ | R _{DS(ON)B} | | | 70 | | mΩ |
| Top Switch Leakage Current | I _{LEAK_TOP} | V _{IN} =24V, V _{EN} =0V, V _{SW} =0V | | 0.1 | 1 | μA |
| Bottom Switch Leakage Current | I _{LEAK_BOT} | V _{IN} =24V, V _{EN} =0V, V _{SW} =24V | | 0.1 | 1 | μA |
| Top Switch Current Limit ⁵⁾ | I _{LIM_TOP} | Minimum Duty Cycle | | 3.8 | | A |
| Switch Frequency | F _{SW} | | 1000 | 1400 | 1800 | kHz |
| Minimum On Time ⁵⁾ | T _{ON_MIN} | | | 60 | | ns |
| Minimum Off Time ⁵⁾ | T _{OFF_MIN} | V _{FB} =0.4V | | 110 | | ns |
| EN Rising threshold voltage | V _{EN_TH} | V _{EN} rising | 1.9 | 2.1 | 2.3 | V |
| EN shut down hysteresis ⁵⁾ | V _{EN_HYST} | | 150 | 180 | 210 | mV |
| Thermal Shutdown ⁵⁾ | T _{TSD} | | | 160 | | °C |
| Thermal Shutdown hysteresis ⁵⁾ | T _{TSD_HYST} | | | 20 | | °C |

Note:

5) Guaranteed by design.

PIN DESCRIPTION

| TSOT23-6 Pin | Name | Description |
|--------------|------|---|
| 1 | GND | Ground. |
| 2 | SW | SW is the switching node that supplies power to the output. Connect the output LC filter from SW to the output load. |
| 3 | VIN | Input voltage pin. VIN supplies power to the IC. Connect a 3.8V to 24V supply to VIN and bypass VIN to GND with a suitably large capacitor to eliminate noise on the input to the IC. |
| 4 | FB | Output feedback pin. FB senses the output voltage and is regulated by the control loop to 0.8V. Connect a resistive divider at FB. |
| 5 | EN | Drive EN pin high to turn on the regulator and low to turn off the regulator. |
| 6 | BST | Bootstrap pin for top switch. A 0.1uF or larger capacitor should be connected between this pin and the SW pin to supply current to the top switch and top switch driver. |

BLOCK DIAGRAM

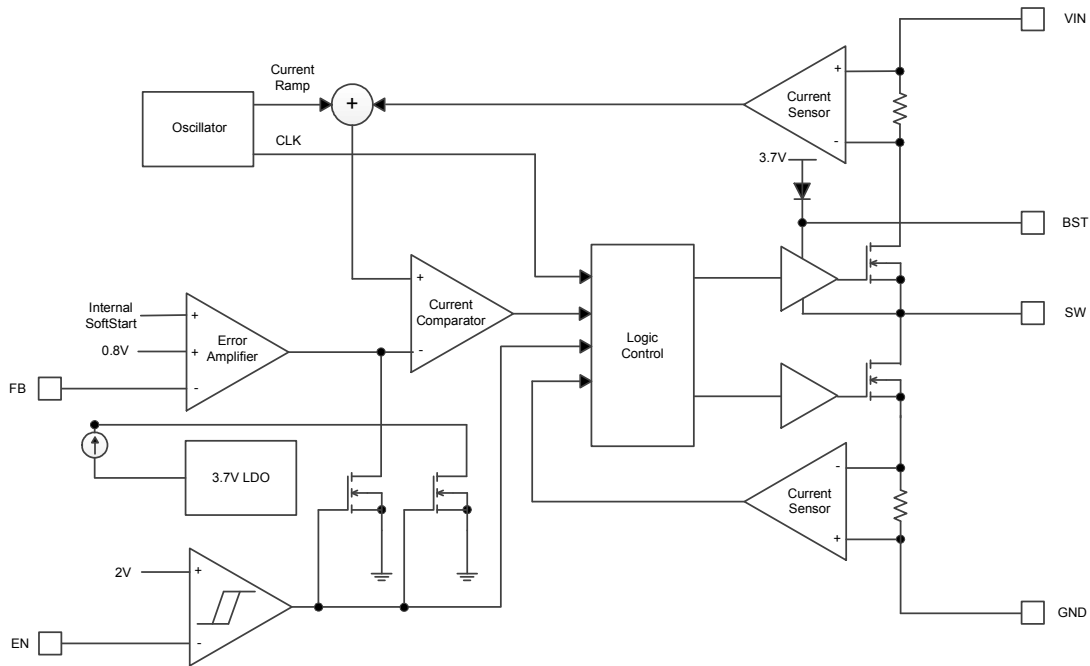

TYPICAL PERFORMANCE CHARACTERISTICS

VIN = 12V, VOUT = 3.3V, L = 4.7μH, Cout = 10μF, TA = +25°C, unless otherwise noted

Steady State Test

VIN=12V, Vout=3.3V
Iout=2A

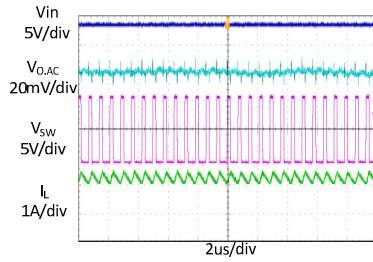

Startup through Enable

VIN=12V, Vout=3.3V
Iout=2A(Resistive load)

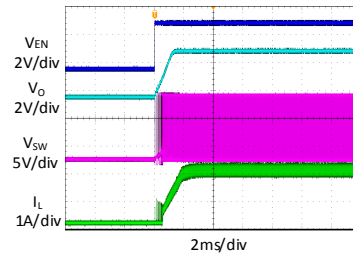

Shutdown through Enable

VIN=12V, Vout=3.3V
Iout=2A(Resistive load)

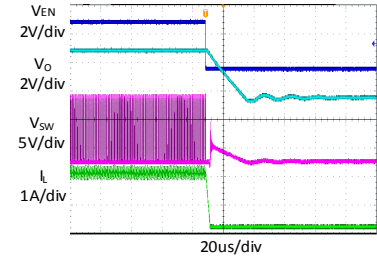

Heavy Load Operation

2A LOAD

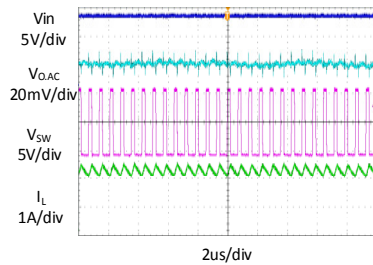

Medium Load Operation

0.2A LOAD

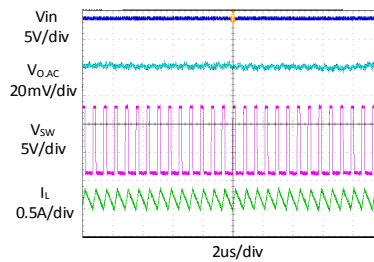

Light Load Operation

0 A LOAD

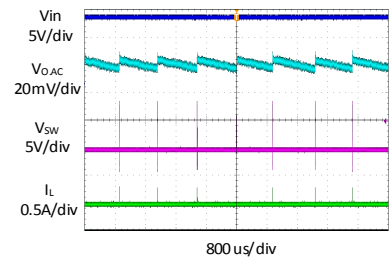

Short Circuit Protection

VIN=12V, Vout=3.3V
Iout=2A- Short

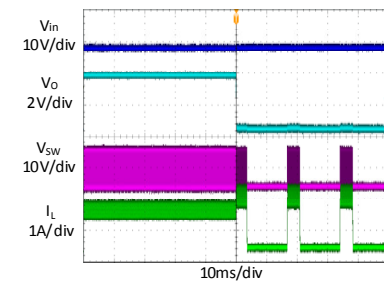

Short Circuit Protection

VIN=12V, Vout=3.3V
Iout= Short -2A

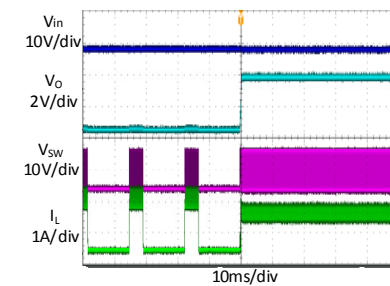

Load Transient

0.2A LOAD → 2A LOAD → 0.2A LOAD

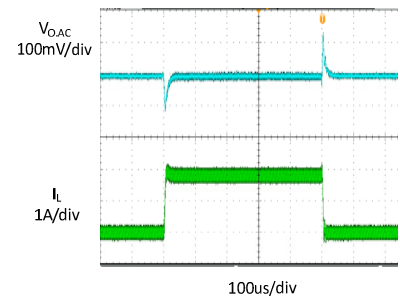

TYPICAL PERFORMANCE CHARACTERISTICS *(continued)*

VIN = 12V, VOUT = 3.3V, L = 4.7μH, Cout = 10μF, TA = +25°C, unless otherwise noted

Load regulation @Vout=3.3V

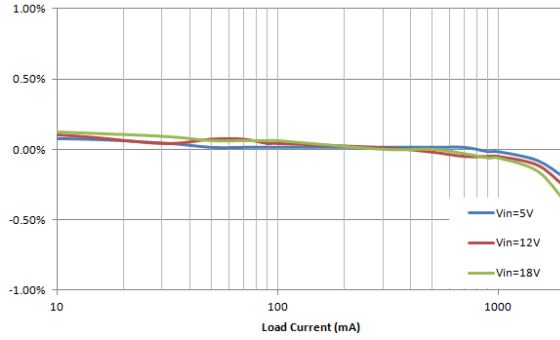

Shutdown Current Vs. Input Voltage

VIN=4.5V ~ 24V, VEN=0V

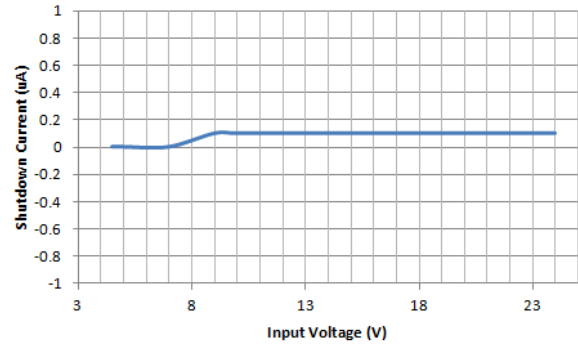

Efficiency @ Vout=3.3V

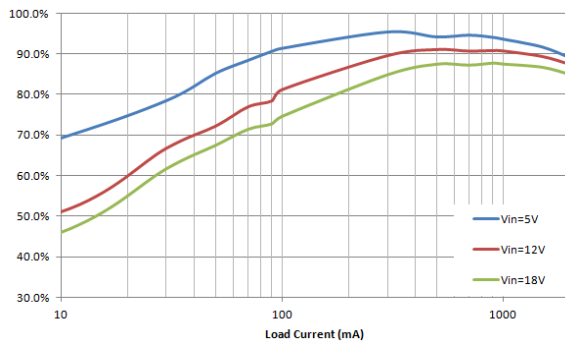

FUNCTIONAL DESCRIPTION

The XR5027 is a synchronous, current-mode, step-down regulator. It regulates input voltages from 3.8V to 24V down to an output voltage as low as 0.8V, and is capable of supplying up to 2A of load current.

Current-Mode Control

The XR5027 utilizes current-mode control to regulate the FB voltage. Voltage at the FB pin is regulated at 0.8V so that by connecting an appropriate resistive divider between VOUT and GND, designed output voltage can be achieved.

PFM Mode

The XR5027 operates in PFM mode at light load. In PFM mode, switch frequency decreases when load current drops to boost power efficiency at light load by reducing switch-loss, while switch frequency increases when load current rises, minimizing output voltage ripples.

Internal Soft-Start.

Soft-Start makes output voltage rising smoothly follow an internal SS voltage until SS voltage is higher than the internal reference voltage. It can prevent overshoot of output voltage when startup.

Power Switch

N-Channel MOSFET switches are integrated on the XR5027 to down convert the input voltage to the regulated output voltage. Since the top MOSFET needs a gate voltage greater than the input voltage, a boost capacitor connected between BST and SW pins is required to drive the gate of the top switch. The boost capacitor is charged by the internal 3.8V rail when SW is

low.

Vin Under-Voltage Protection

A resistive divider can be connected between Vin and GND, with the central tap connected to EN, so that when Vin drops to the pre-set value, EN drops below 2V to trigger input under voltage lockout protection.

Output Current Run-Away Protection

At start-up, due to the high voltage at input and low voltage at output, current inertia of the output inductance can be easily built up, resulting in a large start-up output current. A valley current limit is designed in the XR5027 so that only when output current drops below the valley current limit can the top power switch be turned on. By such control mechanism, the output current at start-up is well controlled.

Over Current Protection and Hiccup

XR5027 has a cycle-by-cycle current limit. When the inductor current triggers current limit, XR5027 enters hiccup mode and periodically restart the chip.

XR5027 will exit hiccup mode while not triggering current limit.

Thermal Protection

When the temperature of the XR5027 rises above 160°C, it is forced into thermal shut-down.

Only when core temperature drops below 140°C can the regulator becomes active again.

APPLICATION INFORMATION

Output Voltage Set

The output voltage is determined by the resistor divider connected at the FB pin, and the voltage ratio is:

$$V_{OUT} = \frac{V_{FB} * (R_1 + R_2)}{R_2}$$

where V_{FB} is the feedback voltage and V_{OUT} is the output voltage.

Choose R_1 around 10k Ω , and then R_2 can be calculated by:

$$R_2 = R_1 * \left(\frac{V_{OUT}}{0.8} - 1 \right)$$

The following table lists the recommended values.

| V _{OUT} (V) | R ₁ (K Ω μ Ω) | R ₂ (K Ω μ Ω) |
|----------------------|---|---|
| 1 | 10.2 | 2.55 |
| 1.2 | 10.2 | 5.11 |
| 1.8 | 10.2 | 12.7 |
| 3.3 | 10.2 | 31.6 |
| 5 | 10.2 | 53.6 |

Input Capacitor

The input capacitor is used to supply the AC input current to the step-down converter and maintaining the DC input voltage. The ripple current through the input capacitor can be calculated by:

$$I_{Cin} = I_{LOAD} * \sqrt{\frac{V_{OUT}}{V_{IN}} * \left(1 - \frac{V_{OUT}}{V_{IN}} \right)}$$

where I_{LOAD} is the load current, V_{OUT} is the output voltage, V_{IN} is the input voltage.

Thus the input capacitor can be calculated by the following equation when the input ripple voltage is determined.

$$C_{in} = \frac{I_{LOAD}}{f_s * \Delta V_{IN}} * \frac{V_{OUT}}{V_{IN}} * \left(1 - \frac{V_{OUT}}{V_{IN}} \right)$$

where C_{in} is the input capacitance value, f_s is the switching frequency, ΔV_{IN} is the input ripple voltage.

The input capacitor can be electrolytic, tantalum or ceramic. To minimizing the potential noise, a small X5R or X7R ceramic capacitor, i.e. 0.1 μ F, should be placed as close to the IC as possible when using electrolytic capacitors.

A 10 μ F ceramic capacitor is recommended in typical application.

Output Capacitor

The output capacitor is required to maintain the DC output voltage, and the capacitance value determines the output ripple voltage. The output voltage ripple can be calculated by:

$$\Delta V_{OUT} = \frac{V_{OUT}}{f_s * L} * \left(1 - \frac{V_{OUT}}{V_{IN}} \right) * \left(R_{ESR} + \frac{1}{8 * f_s * C_{out}} \right)$$

where C_{out} is the output capacitance value and R_{ESR} is the equivalent series resistance value of the output capacitor.

The output capacitor can be low ESR electrolytic, tantalum or ceramic, which lower ESR capacitors get lower output ripple voltage.

The output capacitors also affect the system stability and transient response, and a 10 μ F ceramic capacitor is recommended in typical application.

Inductor

The inductor is used to supply constant current to the output load, and the value determines the ripple current which affect the efficiency and the output voltage ripple. The ripple current is typically allowed to be 40% of the maximum

switch current limit, thus the inductance value can be calculated by:

$$L = \frac{V_{OUT}}{f_s * \Delta I_L} * \left(1 - \frac{V_{OUT}}{V_{IN}}\right)$$

where V_{IN} is the input voltage, V_{OUT} is the output voltage, f_s is the switching frequency, and ΔI_L is the peak-to-peak inductor ripple current.

External Bootstrap Capacitor

A bootstrap capacitor is required to supply voltage to the top switch driver. A 0.1 μ F low ESR ceramic capacitor is recommended to be connected to the BST pin and SW pin.

PCB Layout Note

For minimum noise problem and best operating performance, the PCB is preferred to following the guidelines as reference.

1. Place the input decoupling capacitor as close to XR5027 (V_{IN} pin and GND) as possible to eliminate noise at the input pin. The loop area formed by input capacitor and GND must be minimized.
2. Put the feedback trace as far away from the inductor and noisy power traces as possible.
3. The ground plane on the PCB should be as large as possible for better heat dissipation.

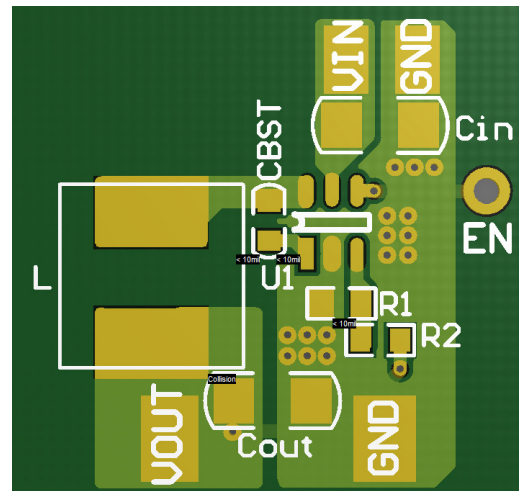

REFERENCE DESIGN

Reference 1:

V_{IN} : 4.7V ~ 24V

V_{OUT} : 3.3V

I_{OUT} : 0~2A

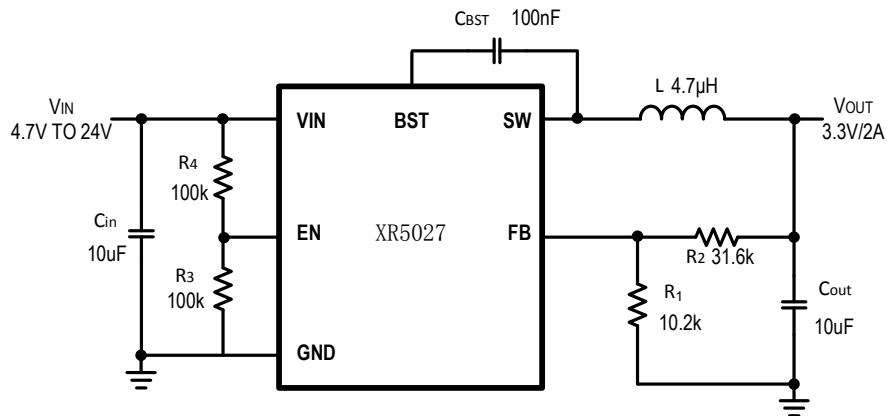

Reference 2:

V_{IN} : 8V ~ 24V

V_{OUT} : 5V

I_{OUT} : 0~2A

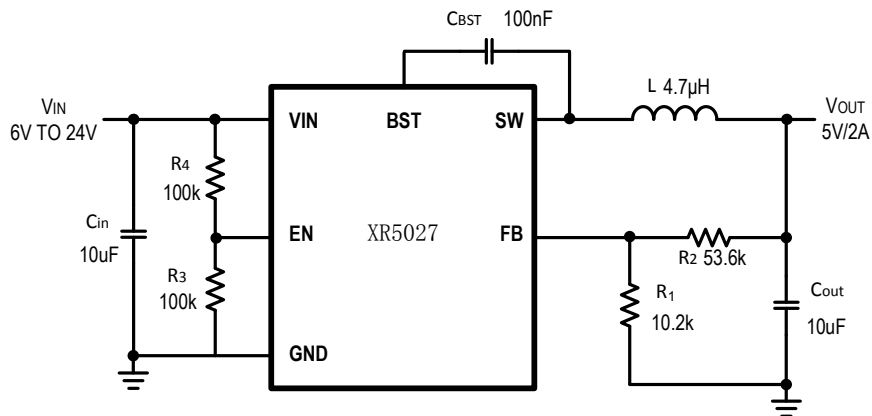

PACKAGE OUTLINE

SOT23-6

UNIT: mm

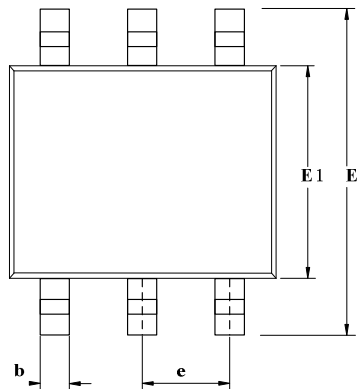
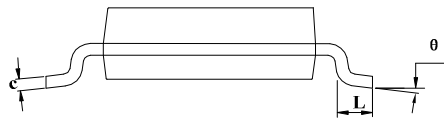
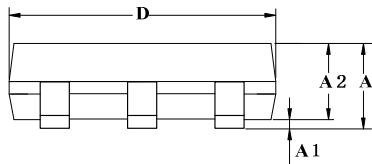

| SYMBOL | MILLIMETER | | |
|----------|------------|------|------|
| | MIN | NOM | MAX |
| A | 1.05 | 1.15 | 1.25 |
| A1 | 0 | 0.05 | 0.15 |
| A2 | 0.95 | 1.05 | 1.20 |
| b | 0.20 | 0.40 | 0.60 |
| c | 0.05 | — | 0.21 |
| D | 2.72 | 2.92 | 3.12 |
| E | 2.60 | 2.80 | 3.00 |
| E1 | 1.40 | 1.60 | 1.80 |
| e | 0.95 (BSC) | | |
| L | 0.30 | 0.45 | 0.60 |
| θ | 0° | — | 8° |